

Tower Cable "Lube Catcher"

Tom Hammond, NØSS v1.2 30 October 2006

This device is intended to catch and 're-direct' the lubricant "overspray" which will inevitably occur when you attempt to hit a 3/8" wide cable with the 2" wide stream from a spray can, 20 feet in the air, in a 20 MPH wind!

Material: Scrap Double-sided-copper PC Board or tin, your choice

I designed the plates such that, when the device is held against the cable, the bottom of the catcher will be canted inward just enough that any caught lubricant will be forced to run toward the back of the catcher and held against the cable.

Without being angled back a bit (by the upper plate), caught lube tends to want to run anywhere... often out the front, instead of toward the rear.

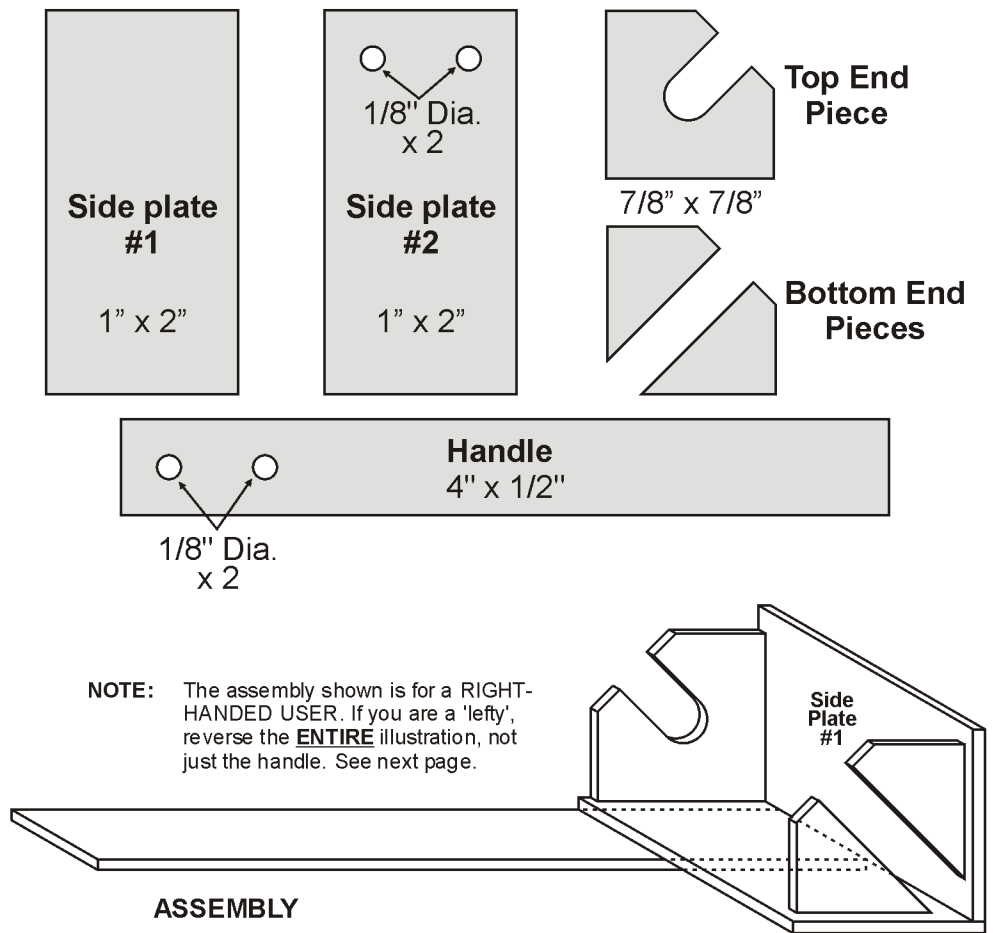

1. Solder the **TOP END** piece to the two **SIDE** pieces.
2. Solder the bottom end of the two sides together.
3. Solder the two **BOTTOM END** pieces to the two side pieces. Ensure that the slot between these pieces is wide enough to pass your cable. **NOTE:** The two **BOTTOM END** pieces are inset about 1/16" above the bottom end of the side pieces, so they can be soldered **ON BOTH SIDES** (for stability).
4. Using two #4-40 X 1/4" screws and nuts, attach the handle to the side piece.

Close-up of an assembled (Left-Handed) 'Lube Catcher'

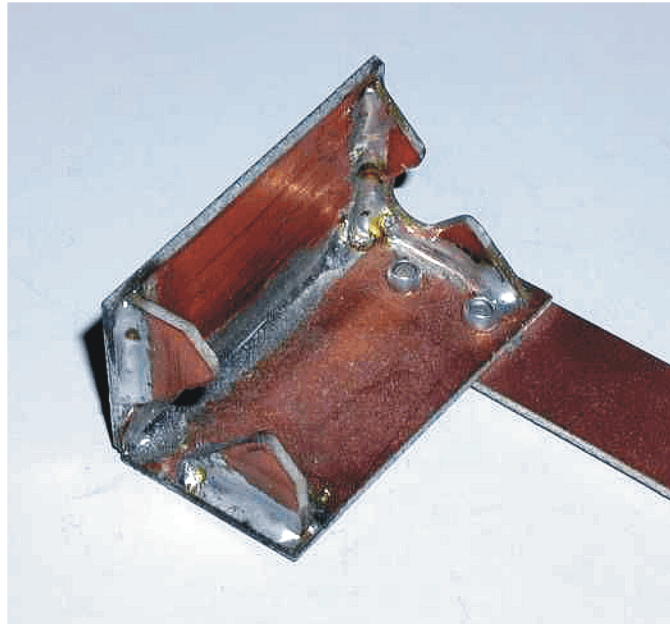

(Left-handed) 'Lube Catcher' in position for use

Lubricant over-spray caught by the 'Lube Catcher' will be channeled to the bottom of the catcher and back onto the cable as the 'catcher' slides further up or down the cable.

Assembly of the 'Lube Catcher' should be dictated by which hand you use to hold the spray can (your 'dominant' hand). Side Plate #2 and the handle should be assembled on the dominant hand side of the device.

