

K6XX SMD Visible LED CW Tuning Indicator

Suggested Assembly & Alignment Instructions - Elecraft K2 Version

by: Tom Hammond, NØSS v2.34 02/15/2005

Attempts to include installation documentation for the Elecraft K2, K1, and KX1 transceivers, all in one single document have caused this document to reach enormous proportions (over 6 MB). As a result, I have broken the documentation out into separate (much smaller) PDFs, each available at my web site. Please download a version specific to your particular radio as shown below:

Radio	File to download
K2	www.n0ss.net/k6xx_cw_tun_ind_smd_v2_assy-align_k2_ver.pdf
K1	www.n0ss.net/k6xx_cw_tun_ind_smd_v2_assy-align_k1_ver.pdf
KX1	www.n0ss.net/k6xx_cw_tun_ind_smd_v2_assy-align_kx1_ver.pdf

If you wish to install the CW Tuning Indicator into any other radio, use the assembly documentation for the K1.

Although in very small print, ALL SMD resistors are appropriately marked with their component value. However, none of the SMD capacitors are so marked. In order to assist in capacitor identification, the tab of each capacitor has been color-tagged, and those colors noted in the assembly instructions. As components are referred to in this document, the color of the tab on their carrier strip will also be noted. Be sure to INVENTORY all of your parts **AND** (and arrange them in order of installation) prior to beginning assembly.

With the exception of the IC, each component resides within the protective plastic or paper 'carrier' in which it was shipped. Resistors and most (if not all) capacitors may be easily pressed out the *back side* of their protective paper carrier. The trimpot, and possibly some caps, will be enclosed in a plastic 'bubble' carrier from which the back 'flap' can be pulled loose. One edge of the back plastic cover will be loose, and can be removed with a knife blade. Perform this step AS you remove each component just prior to its installation.

INVENTORY AND ORGANIZE YOUR COMPONENTS

Quantity	Component
1 []	PC board
1 []	NJM2211M PLL (foil-wrapped), U1
1 []	.022uF SMD capacitor (BLU tab)
1 []	0.1uF SMD capacitor (YEL tab). This is the temp-stable PLL timing capacitor CT , and should <i>NOT</i> to be confused with the three RED-tabbed 'common' capacitors listed below.
3 []	0.1uF SMD capacitor (RED tab)
1 []	0.33uF SMD capacitor (GRN tab)
1 []	0-Ohms (000) SMD resistor, RLED
1 []	3.3k (332) SMD resistor, RLED , NOTE : This resistor is NOT REQUIRED for the Elecraft K2
1 []	6.8k (682) SMD resistor, RLED , NOTE : This resistor is NOT REQUIRED for the Elecraft K2
1 []	11k (113) SMD resistor, RT1 , for a PLL tuning range of approx. 480-890 Hz. Builder's choice
1 []	15k (153) SMD resistor, RT1 , for a PLL tuning range of approx. 400-700 Hz. Builder's choice
1 []	390k (394) SMD resistor
1 []	470k (474) SMD resistor
1 []	10k SMD trimpot, RT2
1 []	5-Pin Male Header
1 []	5-pin Female Receptacle
5 []	Socket pins for 5-pin receptacle, above
1 []	PC board 'SMD holder'
1 []	6-inches, 0.020" dia. Multicore solder. This should be several times the amount you will need!!

If you have never assembled an SMD kit before (as I had not, before having built the prototype of this kit), you may find it difficult to make the tiny SMDs 'behave' and to keep them in place during the soldering procedure.

I tried a number of different devices to hold the SMD in place as it was being soldered at one end. I tried the tip of an ice pick, the blade of an Xacto (craft) knife, a small screwdriver blade, and several other devices. None were found to be really satisfactory, and several tended to want to place the SMD somewhere 'in orbit' around the workbench, but definitely NOT on the PC board. What I found to work best (so far at least) was a short length of PC board which I'd trimmed from one of my prototype boards, my 'SMD holding stick'. Since having used the 'holding stick' for a while, I've come to feel that a 'blunted' toothpick works as well, if not better, mainly because the end of the wooden toothpick is a bit 'softer' and there's less tendency to make the holder slip when it's holding the SMD in place. **Additionally**, and this is a benefit, once you're finished using the blunted end of the toothpick to hold the SMDs in place, the pointed end of the toothpick can then be used to plug the #4 pin of the header receptacle to prevent backward installation of that connector onto the PC board header (see notes later in these docs). So **DO NOT discard the toothpick quite yet!** I found that once I managed to get the SMD properly placed on the PC board (using a sharp-pointed **non-magnetic** soldering aide), it was an easy matter to hold the toothpick 'SMD holding stick' vertically and to place it directly onto the SMD, exerting a small amount of downward pressure on the case of the SMD. I think the slightly broader contact area of the 'blunted stick' helped to steady both the it and the SMD during the soldering process. I am including a toothpick 'holding stick' with the parts. I hope you will find it to be useful.

NOTE

It is **IMPERATIVE** that you use solder which is no larger than 0.020" (0.5 mm) diameter, and 0.015" (0.38 mm) would be a better choice if available. Using larger diameter solders will result in the instantaneous application of excessive solder to the joint as soon as the solder touches the tip of the soldering iron.

Additionally, use the smallest tip you might have for your soldering iron. I used a 'needle' tip (0.02" / 0.5mm radius) during my assembly of the prototype and found that it was none too small. If you have a temp-controlled iron, set your tip temperature for 700 to 725 °F (370-385 °C), and work quickly, to reduce the dwell time on the tiny PC board pads. The shorter the dwell time on a pad, the less chance there is of lifting a pad.

ALWAYS confirm proper component placement **BEFORE** you apply heat the first time, **AND** before you complete the soldering operation to permanently attach remaining pins.

PRE-PREPARATION OF THE IC

The NJM2211 SMD IC used in this project has 'gull wing' legs. **BEFORE** you attempt to solder this device onto the PC board, take time to ensure that none of its legs are improperly bent and that when the IC is setting on a flat surface, all of the legs touch the top of the surface. If any of the legs do not touch the flat surface, **CAREFULLY** bend them into place at this time.

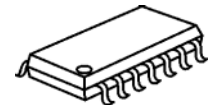

PC BOARD ASSEMBLY (Elecrafit K2 Version)

Please perform the following assembly instructions in the order they are presented. I feel this order will yield the most efficient assembly. A couple builders have suggested that the IC should be installed last. My rationale behind installing it first was to make it as easy for first-time SMD kit builders to access the closely-spaced IC pins as possible, without any concern for having to negotiate among previously installed components. If course, you may use the installation order you feel is most comfortable for you.

One builder noted that since the PC board was so small and light-weight, he found it best if he taped the PC board to another (larger) piece of PC board (or a piece of cardboard), in order to stabilize it during component installation.

- 1) Position the PC board with the date "10-05-04" label at the bottom.
- 2) Using 0.020" or smaller diameter solder, **LIGHTLY** tin the #1 and #8 IC pads on the PC board.
- 3) From the parts package, locate the IC and note its #1 pin, next to the dot embossed into the plastic case of the IC.
- 4) Position the IC with its #1 pin to the top left corner of the PC board pads for this device. Refer to the illustration (right) if you have any questions.

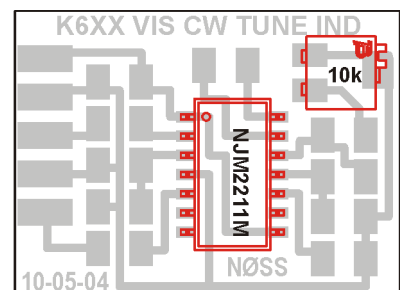

- 5) Using your SMD 'holder' press straight down on the IC body and touch the tip of your soldering iron to the #1 pin, until it is secured to the PC board via the solder used to tin the PC board pad.
- 6) Double-check the positioning of the IC. Make any minor adjustments and then repeat step 5 for IC pin #8. Confirm that all of the legs of the IC are now flush against their matching PC board pads.
- 7) Once you are completely satisfied with the positioning of the IC, use very little solder and connect all of the remaining IC pins to their pads on the PC board. If required, you may now reheat and add just a bit more solder to the #1 & #8 pins of the IC as well.
- 8) Check for solder shorts between pins of the IC and clean up any potential problem areas at this time.
- 9) On the PC board, locate the three pads for the trimpot. Refer to the illustration if needed. Tin the trimpot PC board pad which is closest to IC pin 14. You may want to leave a small amount of solder on this pad as it will be required to facilitate the attachment of the trimpot in the next step.
- 10) Locate the trimpot (RT2) and position it on the PC board such that you can access the tinned pad on the PC board.
- 11) Hold the trimpot in place and place the tip of your iron at the junction of the tinned pad and the solder tab of the trimpot. You may want to add a (very) small amount of solder to the tip of your iron before you make this connection, to help the heat to quickly distribute from the tip of the iron to the PC board pad and the tab on the trimpot. If it takes more than 3-4 seconds to make this connection, STOP, allow the trimpot to cool, then use a knife blade (fine grit emery cloth, steel wool, or a 3M ScotchBrite pad) to clean the trimpot tabs to bright metal. Then, **lightly** tin the first trimpot tab to be soldered and re-attempt this step.
- 12) Recheck the position of the trimpot and solder the two remaining tabs to the PC board using a minimum of solder.
- 13) Using the parts layout illustration to the right, locate and lightly tin (only) the innermost pad (closest to the IC) of all of the caps and resistors. For the 0.1uF cap (CT), centered above the IC, tin the pad closest to the trimpot.

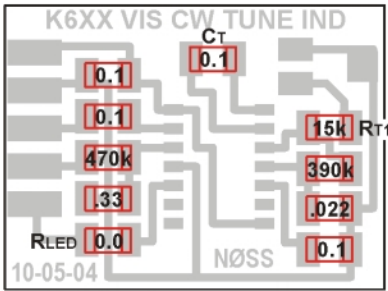

- 14) In the following steps you will install a number of 1206-size SMD devices. Position the component over its pads, holding it in position with slight vertical pressure from the PC board holding strip. Apply heat at the junction of the device's end cap **and** the tinned PC board pad until you see the solder flow. As the solder flows, the device should drop down, flush against the PC board. Continue to hold the SMD in place until the joint has cooled.

DO NOT solder the other end of any of these devices at this time.

Repeat this step for each device.

- 15) Using the parts layout illustration above, select and install components in the following order:

Device	Install Location
[] 0.1 uF C0G SMD cap. (YEL tape)	Above the IC, centered on the PC board. This is CT , the temp-stable, YELLOW tab , capacitor, not one of the 'common' (RED tab) 0.1uF caps, below
[] 0.1uF SMD cap. (RED tape)	Install in upper-left corner of the PC board
[] 0.1uF SMD cap. (RED tape)	Install below the 0.1uF cap, above
[] 470k (474) SMD resistor.	Install below the 2nd 0.1uF cap
[] 0.33uF SMD cap. (GRN tape)	Install below the 470k resistor
[] 0-Ohm (000) SMD resistor (RLED)	Install below the 0.33uF cap, bottom-left corner of PC board
[] 15k (153) SMD resistor	Install below the trimpot, right side of PC board. This (15k) resistor gives a tuning range of about 400-700 Hz. For tuning range of about 480-890 Hz install the supplied 11k (113) SMD resistor
[] 390k (394) SMD resistor	Install below the 15k resistor
[] .022uF SMD cap. (BLUE tape)	Install below the 390k resistor
[] 0.1uF SMD cap. (RED tape)	Install below the .022uF cap

At this point, all available SMD PC board pads should be populated and you should have one (1) 3.3k (**332**), one (1) 6.8k (**682**), either one (1) 11k (**113**) or one (1) 15k (**153**) SMD resistor remaining.

- 16) Once all devices (resistors, capacitors) have been attached at one end and you have confirmed proper placement, proceed to solder the other end of each component to the PC board, using a minimum of solder.
- 17) If you feel the need to do so, re-flow the solder at the FIRST end cap of each device soldered to the PC board.
- 18) This completes SMD component mounting.
- 19) Lightly tin the #1 PC board pad for the 5-pin (male) header.

20) Refer to the illustration below and locate the 5-pin (male) header. Place it in position against the PC board pads and with the bottom of the plastic holder flush against the side of the PC board.

21) Heat the junction of pin #1 of the 5-pin header and the PC board and solder it to the PC board.

22) Confirm proper positioning of the 5-pin header, then solder the four remaining pins to the PC board.

23) This completes the assembly of the PC board.

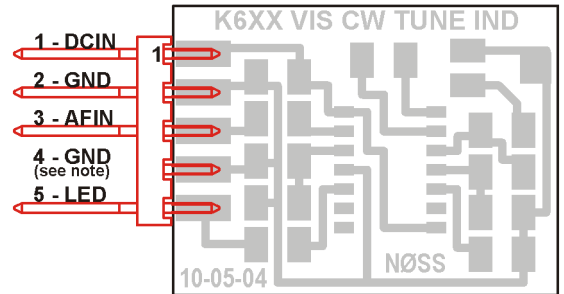

AS A SAFETY PRECAUTION...

The following steps are NOT 'required', but they are suggested in order to ensure that the header receptacle is not installed 180 degrees out of position, **if** you are not using PIN 4 (GND) of the Tuning Indicator in your particular installation:

- A) Close-clip pin 4 (AF GND) on the 5-pin header soldered to the PC board. Cut it off flush to the body of the header.
- B) Insert a toothpick as far into pin 4 of the black header receptacle as it will go, then flush-cut it with the end of the receptacle. This will sufficiently protect you from accidentally mis-plugging the two connectors.

Note: If you wish to implement this option, but **do** need to have two separate GND lines, you can always install a 2nd wire at pin 2 of the header receptacle. This will allow you to have two GND lines, while leaving pin 4 unused.

INSTALLATION INSTRUCTIONS FOR THE ELECFRAFT K2 TRANSCEIVER

A couple of builders have commented that they spent an unusually long time preparing the wires and pins for the 5-pin header receptacle. I am not certain why this should be the case. For what it may be worth, here is how I do it.

24) Strip and lightly tin ONE END of four (4) 4-inch (10 cm) long wires (the #26 *stranded* wires from computer ribbon cable work very well in this application).

25) Secure the body of the AMP header receptacle in a small desk vise, as shown in the illustration at right. Do **not** overtighten the jaws of the vise, but snug them down to the point that the receptacle will not move while you are soldering to the individual pins.

26) Insert one of the receptacle pins (wings **up**) into the topmost channel of the receptacle just to the point that the pin is held rather securely by the receptacle.

27) Using a fine-tipped soldering iron, melt a **small** amount of solder into the channel of the receptacle pin in the area between the two larger 'wings' of the pin.

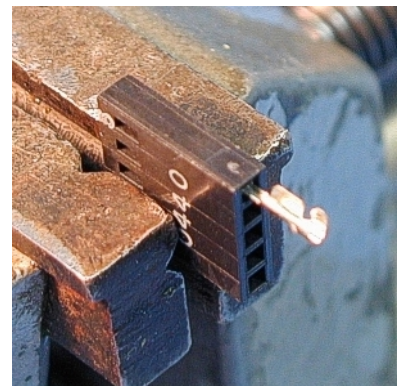

- 28) Lay the tinned end of the wire prepared in step 24 (above) into the tinned area of the pin and touch the joint with your soldering iron to melt the solder in the channel and to allow the wire to drop down into it. Hold the wire steady until the joint cools. Remove the pin and wire from the AMP receptacle.
- 29) Fold the (4) wings of the receptacle pin inward **just** enough to allow the pin to (later) be installed easily, without requiring excessive pressure to force in into the receptacle. The wings **do not** have to be bent flat.
- 30) Repeat steps 26 through 29 for each of the remaining wires.
- 31) Refer to the illustration, below. Position the black plastic receptacle with the word "AMP" at the top. In this position, the pins are numbered #1 thru #5, starting from the TOP of the receptacle. Note that there is a locking tab on each pin. Be sure you have this tab inserted into the receptacle so it will latch into the small rectangular slot in the receptacle. Insert the wired socket pins into receptacle holes 1, 2, 3 and 5. Do **not** install a receptacle pin into the pin #4 hole.
- 32) Once the wires have been installed into the 5-pin receptacle, cut the wires to the following lengths (measured from the back edge of the black receptacle):

Pin 1	DCIN	1-1/2" (3.8 cm)
Pin 2	GND	3" (7.6 cm)
Pin 3	AFIN	3" (7.6 cm)
Pin 5	LED	1-3/8" 3.5 cm)

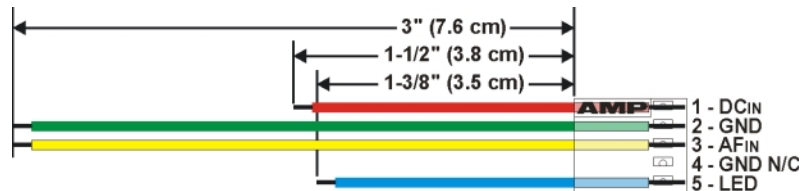

- 33) Strip 1/8" (3 mm) of insulation from the end of each wire and tin the end.
- 34) Remove the top cover of the K2.
- 35) If the KAF2 or KDSP2 is installed, remove it from the Control board, also remove any other hardware securing the Control Board to the Front Panel board.
- 36) Remove the four (4) 4-40 x 1/4" screws holding the Front Panel of the K2 to the case, and pull the front panel (and FP board) away from the front of the K2 case.
- 37) Using the installation illustrations (1st page following Troubleshooting notes), connect the four wires from the PC board as shown.

YOU HAVE NOW COMPLETED THE ASSEMBLY PHASE!

ALIGNMENT IN THE ELECRAFT K2 TRANSCEIVER

- 38) For K2 installations, refer to the suggested installation illustration (page 10), and close-trim (preferably flush-trim) all component leads on the bottom side of both the Front Panel and the Control PC boards in the area where the Tuning Indicator will eventually be located. This will help to reduce any chances of accidental shorts between a K2 PC board and the CW tuning Indicator PC board once the device is installed.
- 39) Reinstall the Front Panel. Secure with a two screws at the top for the moment.

Ensure that the CW Tuning Indicator PC board has been (temporarily) installed so it is now resting outside of the K2 cabinet, that the adjusting screw of the trimpot can be easily accessed for adjustment, AND that the none of the components on the Indicator PC board can short out to the K2 case or components.
- 40) If one was previously installed, reinstall the KAF2 or KDSP2 at this time.
- 41) Connect power to the K2 and turn the rig on. CHECK FOR SMOKE!
- 42) Select the 80M band and tune in the birdie which appears just at 4.000 MHz.
- 43) Press-hold [**SPOT**] to enable the sidetone.
- 44) If the SPOT tone is significantly stronger (or weaker) than the tone being received from the 4.000 MHz birdie, adjust the AF GAIN control to make the two tones about the same level. Note that you may also wish to use MENU | ST L to change the SIDETONE level, though merely adjusting the AF GAIN may be sufficient.
- 45) With the VFO tuning rate set to 10 Hz resolution, slowly tune the VFO to being the tone from the 4.000 MHz birdie to the same tonal frequency as that of the SPOT tone. You will know when you have accomplished this as the tone from the 4.000 MHz birdie will seem to 'disappear' behind the SPOT tone, and you may hear a slow 'beat' note (pulsing of the two tones). If you hear a beat note, continue to tune the VFO until the speed of the beat note is as slow as possible. Press [**SPOT**] to turn the SPOT tone off.
- 46) Using a very small-bladed screwdriver, slowly adjust the 5-turn trimpot until the 10th LED of the K2 S-meter just starts to flash, and then turns on solidly (brightly). Note the rotational position of the screwdriver (place a mark, or a 'flag', on the screwdriver if necessary). Continue to turn the screwdriver in the same direction. The LED will remain brightly lit for about 40 Hz of VFO adjustment and then again return to flashing slowly as you tune past the point of maximum LED brilliance. STOP TUNING HERE, and reverse the VFO tuning until the LED again just lights solidly. Note this second point of rotation of the screwdriver, which should occur about 1 to 2 turns past the point where the LED first started blinking slowly.
- 47) Reverse the direction of the screwdriver and set it to midway between the two points at which the LED flashed slowly.
- 48) Set the K2 to the 40M band, and the weak birdie at 7.000 MHz.
- 49) Refer to steps 43 thru 45, and zero beat the 7.000 MHz birdie against the SPOT tone. NOTE the VFO frequency on paper.
- 50) With the VFO still set to 10 Hz resolution, tune back and forth, across the zero beat frequency you wrote on paper in the above step. You should note that the LED changes from solid (bright) illumination to flashing at about 20-30 Hz either side of the center frequency, and that it lights more solidly the closer you get to being dead-on zero beat with the SPOT tone.
- 51) This completes alignment of the CW Tuning Indicator.
- 52) **Insulate the component side of the PC board, to prevent its components from shorting out to components on the FP or CTRL boards. Use plastic tape, heat shrink, or other means to ensure against shorts.** Then drop the PC board in between the FP and CTRL boards and complete the re-assembly of your K2.

You are finished!

OPERATIONAL NOTES

A few words might be appropriate about the operating 'characteristics' of this device. It is **not** unusual for the 10th S-meter LED segment to frequently blink dimly even though there appears to be no signal present. This is the PLL responding to on-frequency background noises which it interprets as a received signal. This effect will generally be more pronounced at narrower bandwidths of the CW filter, as slightly more 'ringing' of the received noise occurs. This is a normal occurrence and should *not* be viewed as a problem. You will quickly find that the Tuning Indicator is quite sensitive to in-band signals and that it will often lock onto a received signal which is almost below your hearing ability. We should view this not as a problem, but rather as an indicator that the PLL is working as intended.

As you tune through a noisy band, you will find that the Tuning Indicator LED will lock onto received signals, and the LED will change from periodically illuminating dimly to lighting more brightly, and much more solidly as you approach having the received signal centered within the passband of the PLL. Once you have the received signal tuned within +/-20 Hz to 30 Hz of the center of the PLL, the LED will blink brightly in time with the keying of the received signal. This indicates that you should be tuned well within the passband of the other station's most narrow CW filter, even within a 100 Hz wide CW filter, if the other station happens to be using one. At this point, you can always turn on your CW spotting tone to confirm that it and the received signal are very close to each other in frequency.

TROUBLESHOOTING NOTES

With a bit of care during assembly, I would not anticipate you will have any problems getting your CW Tuning Indicator to function from the time power is first applied. However, there is always that small change that something will go wrong. I offer these suggestions as possible troubleshooting tips:

1. **Clean up your act!** Quite often, failures can be traced directly to poor assembly practices... or not having taken your time during assembly.

Confirm that ALL connections are well soldered. At least one 'failure' was fixed when the builder realized that when he attached the 5-pin header to the PC board, he's only applied solder to several of the PINS and not to the PADS. This was probably the result of being in too much of a hurry to complete the kit, and not taking time to ensure that solder had properly flowed between both the pins **and** the pads to which they were being soldered.

Confirm that you have applied solder to **all** of the IC pads, and that the solder has flowed between the pads and the IC pins. Another momentary failure was 'mysteriously' fixed when the builder used solder wick to remove all excess solder from the 2211 IC pins. Apparently, he either had one or more solder shorts between pins, **or** one or more pins not soldered to the pads. Either way, the act of 'wicking' away the solder either removed the solder short or succeeded in connecting a missing pin to its appropriate PC board pad. Following this action, the circuit came to life.

Confirm that you have the correct components installed in the correct board locations. This is particularly true for those components on the right hand side of the PC board and at the top of the board.

2. If cleaning things up doesn't solve the problem, check to confirm that the PLL will find a lock somewhere within the audio range, even if not at the frequency at which you wish to have it lock.

If the frequency at which you wish to have the PLL lock is toward to lower end of the PLL's tuning range (in the 400-450 Hz range), try providing a tone around 500-600 Hz, and then tuning the trimpot to see if the PLL will indicate a lock (illuminated LED). If the PLL will achieve a lock somewhere between 400 and 800 Hz, you then know that it is working, just not at the desired frequency.

If the PLL **can** find a lock somewhere within the normal audio range (400-800 Hz):

Turn the trimpot to one end of its tuning range (some resistance will be felt when you tune to the end of the tuning range), and then tune the tone source (receiver) until the received tone causes the PLL to lock, illuminating the LED. This indicates either the upper or lower boundary of the PLL tuning range. Now, turn the trimpot to the other end of its range and repeat this test. At this point you will now have an audible indication of the upper and lower boundary of the current PLL tuning range.

If the **bottom** of the current PLL tuning range is slightly above the frequency you wish to set the PLL to tune, you will require a slightly **higher** resistance at **RT1** (something around 18k-22k). Conversely, if the **upper** boundary of

the current PLL tuning range is just below the frequency at which you want it to lock, you will require a slightly **lower** resistance at **RT1** (something around 12k-10k).

If the PLL **cannot** find a lock anywhere within the normal CW tuning range (400-800 Hz):

With the K2 turned ON, and the Tuning Indicator installed, using a resistor in the range of 1k to 3.9k, **CAREFULLY(!)** connect the resistor between pin 5 (LED) of the 5-pin header and pin 4 (GND) of the 5-pin header. If this causes the LED to illuminate, then you know the LED is properly connected. If it does not illuminate, check the LED polarity If it is not installed in an Elecraft K2), and the connection to the LED itself.

Double-check all of your connection points, especially the connection point for the AF In lead.

Listed below are some representative voltage and resistance readings, taken from a known-good SMD version of the K6XX CW Tuning Indicator installed in an Elecraft K2:

K6XX CW Tuning Indicator - SMD Version

Representative Resistance & Voltage Readings

Note: ALL voltage readings were taken when attached to an Elecraft K2 radio. Readings may vary somewhat, depending upon the radio into which you have the device installed.

Resistances

Test Conditions:

CW Tuning Indicator UNplugged from radio
Measurement device: Fluke 187 DMM
DMM Negative Lead: connected to PC board header Pin 2 (GND)

2211 Pin	Approx. Resistance
1	6 M
2	11 M
3	400 k
4	0
5	>6 M
6	>10 M
7	>10 M
8	6 M
9	>10 M
10	4 M
11	400 k
12	38 k
13	>10 k
14	9 M

(continued on next page)

DC Voltage Readings

Test Conditions:

CW Tuning Indicator connected to radio
Radio turned ON Band: 75M (4.000 MHz birdie)
AGC: ON / FAST PREamp: OFF
Measurement device: Fluke 187 DMM
DMM Negative Lead: connected to PC board header Pin 2 (GND)

2211 Pin	NO-LOCK DC Volts	IN-LOCK DC Volts
1	5.0	5.0
2	2.5	2.5
3	0.2	4.8
4	0	0
5	1.6	0
6	<0.03	0.1
7	0.1	0.1
8	5.0	5.0
9	<0.01	0.04
10	1.7	1.7
11	1.0	0.1
12	1.7	1.7
13	2.8	2.8
14	2.8	2.8

AC Voltage Readings

Test Conditions:

CW Tuning Indicator: connected to radio
Radio turned ON Band: 75M (4.000 MHz birdie)
AGC: ON / FAST PREamp: OFF
Measurement device: Tektronix 2236 oscilloscope, X1 probe
Negative Lead: connected to PC board header Pin 2 (GND)

2211 Pin	NO-LOCK AC Volts	IN-LOCK AC Volts
1	0	0
2	50-100 mV	50-100 mV (AF Input from 4 MHz birdie)
3	Varies, around 2V	0
4	0	0
5	0	0
6	0	0
7	0	0
8	0	0
9	0	0
10	0	0
11	Varies, around 4V	1.0-3.0
12	0	0
13	1.0	1.0
14	1.0	1.0

Suggested Installation of the SMD version of the K6XX Visible CW Tuning Indicator in the Elecraft K2

v2r2 11/23/2004

This device will install between the K2 Front Panel and Control PC boards, in the space slightly behind and just to the right of the DS2 S-meter LED bar display.

Before installation, flush-trim all component leads on the bottom side of both the Front Panel and the Control PC boards in and around the area where the CW Tuning Indicator PC board will be installed. This will greatly reduce any chances of unintentional shorts once the PC board is installed.

Before installing the PC board, protect it from shorting to either the FP or CTRL board. Wrap the PC board in several layers of electrical tape, attach an insulating cover to the component side, or enclose the PC board in

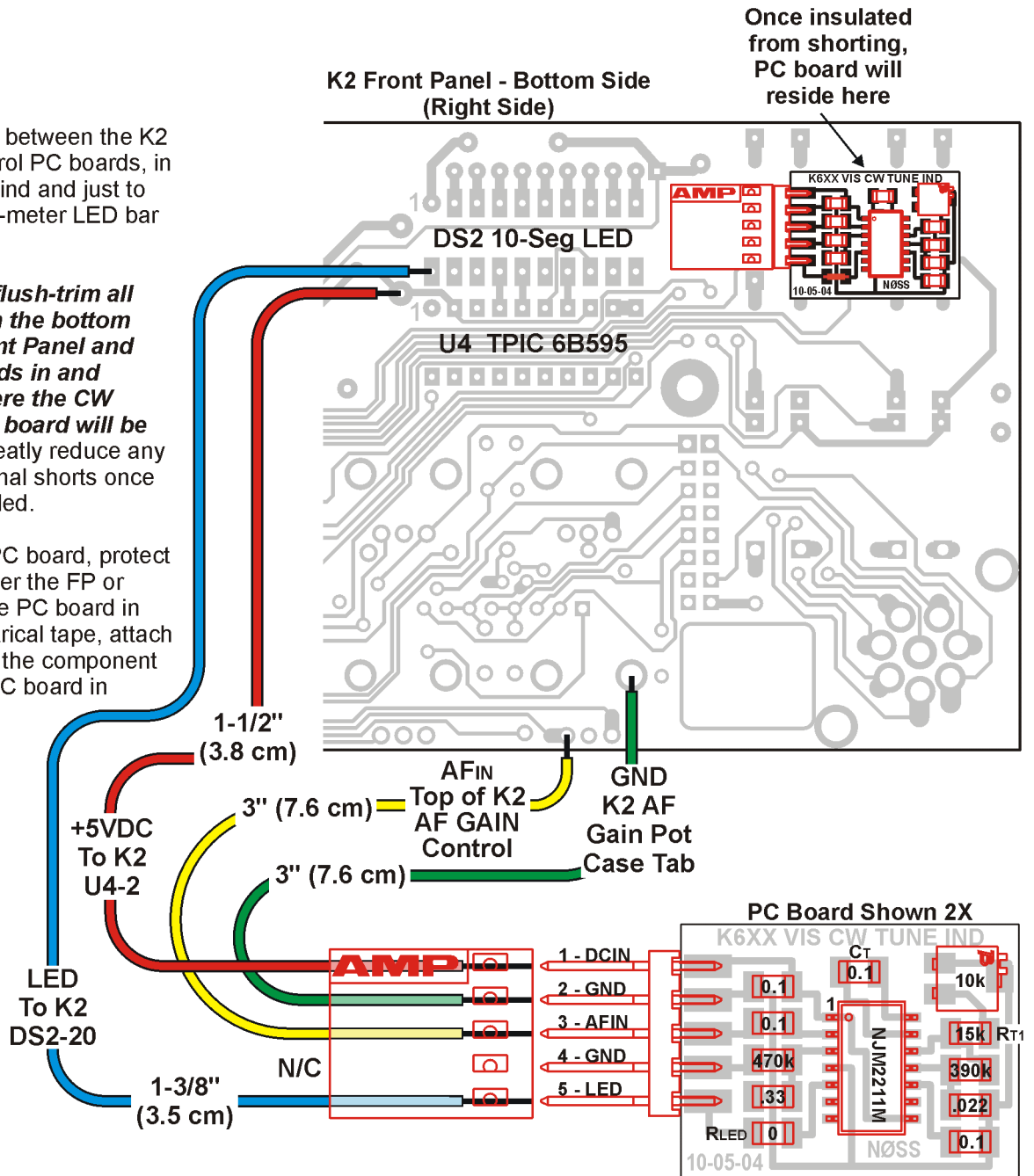

K6XX's Visible CW Tuning Indicator SMD Version

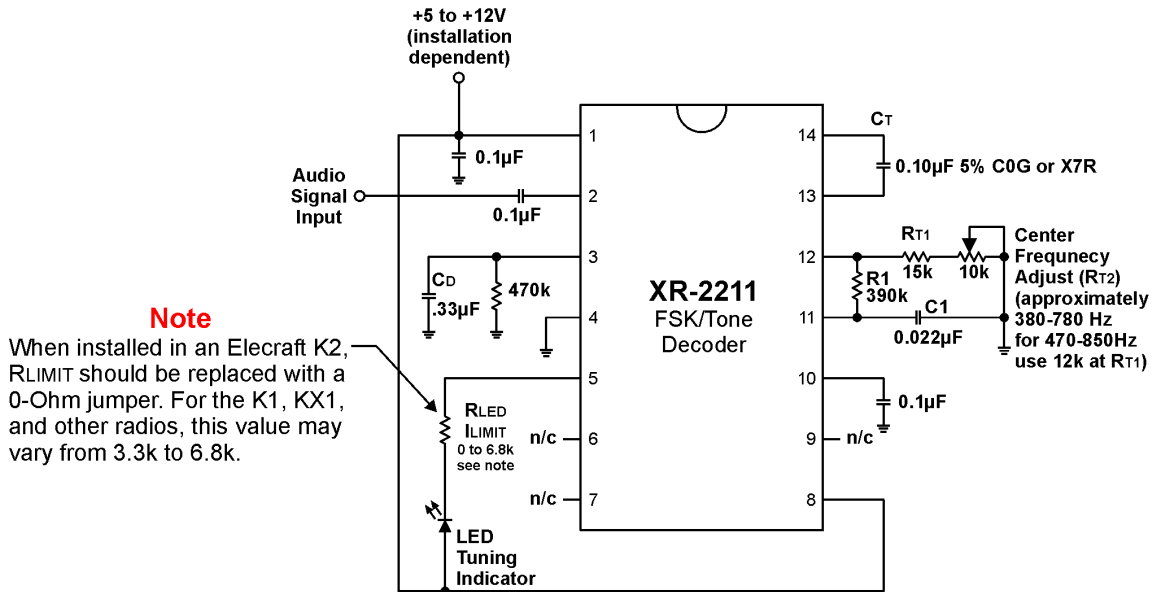

K6XX 'Visible' CW Tuning Indicator - Parts List

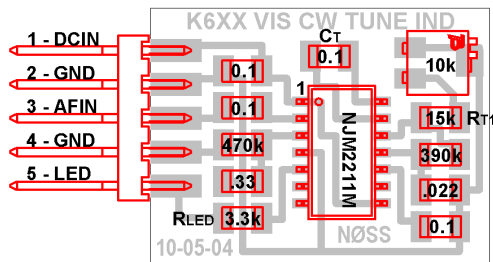

PC Board as Viewed from COMPONENT Side

PC Board Size: 1.00" x 0.75"

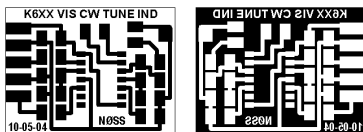

Quan.	Component	Mouser Part #
1	AVX SMD 1206 Cer Chip Cap 5% X7R 0.10uF 50V (CT)	581-12065C104J
1	Xicon SMD Film Chip Cap 1206 50V X7R .022uF (C1)	140-CC502B223K
3	Xicon 1206 SMD Cer Chip Cap 50V 0.1uF	140-CC502B104K
1	Murata 1206 SMD Cer. Chip Capacitor .33UF 25V (Cd)	81-GRM426X334K50D
1	Xicon 1/8W SMD 1206 Film Resistor 0-Ohms RLED (LIMIT)	263-0 for K2
1	Xicon 1/8W SMD 1206 Film Resistor 3.3k RLED (LIMIT)	263-3.3k for K1 / KX1
1	Xicon 1/8W SMD 1206 Film Resistor 6.8k RLED (LIMIT)	263-6.8k for K1 / KX1
1	Xicon 1/8W SMD Film Resistor 15K OHM 5% (RT1)	263-15K
1	Xicon 1/8W SMD (R1)	263-390K
1	Xicon 1/8W SMD (RD) Resistor 470K OHM 5%	263-470K
1	Bourns 4mm 5-Turn SMD Trimmer 10K (RT2)	652-3214J-1-103E
1	NJR SMD DMP14 Demod/Decod Equiv. to Exar XR-2211	513-NJM2211M
1	LED, if required (not supplied)	

OFF-BOARD CONNECTOR

1	5-Pin Header	571-1029765
1	5-Pin Receptacle	571-874999
5	Receptacle Contact	571-860163